



RE-AL

KESİCİ TAKIMLARI & TEKNİK HIRDAVAT SAN. TİC.

HASSAS ÖLÇÜ ALETLERİ ve KALIP BAĞLAMA EKİPMANLARI







Vidalı Yükseltici Bağlama Set

Sipariş No				DIN 6379 d x L 
1990-1012	M10x12	265x255	6000	M10x80-100-160-200
1990-1214	M12x14	305x255	8000	M12x80-100-160-200
1990-1416	M14x16	435-255	13500	M14x80-100-160-200
1990-1618	M16x18	435-255	15000	M16x80-100-160-200
1990-1820	M18x20	495x255	16500	M18x80-100-160-200
1990-2022	M20x22	540x255	18500	M20x100-125-160-200





Merdiven Yükseltici Bağlama Set

Sipariş No				DIN 6379 d x L 
2010-1012	M10x12	330x255	6000	M10x80-100-160-200
2010-1214	M12x14	380x255	8000	M10x80-100-160-200
2010-1416	M14x16	435x255	13500	M14x80-100-160-200
2010-1618	M16x18	435x255	15000	M16x80-100-160-200
2010-1820	M18x20	495x255	16500	M18x80-100-160-200



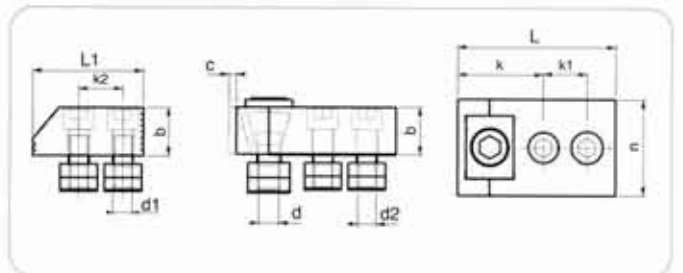

T Kanal Temizleyici

Sipariş No		
1950-1214	12-14	40
1950-1618	16-18	50
1950-2022	20-22	55
1950-2428	24-28	80



Dereceli Yandan Sıkma Set

Sipariş No		c	L	b	n	k	k1	k2	L1	d	d1	d2	Sıkma Kuvveti Clamping Force kgf	
2030-14	14	5	90	23	47	47	26	26	65	M12	M12	M12	2000	3600
2030-16	16													
2030-18	18													
2030-20	20	5	95	28	57	52	26	26	65	M14	M12	M12	2500	4200
2030-22	22													
2030-24	24													
2030-28	28													

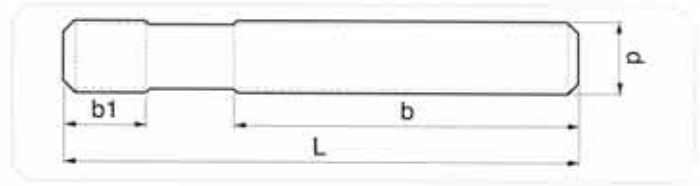

Düz Saplama

Sipariş No	d	L	b1	b	(g)
1690 - 08040	M8	x40	11	20	10
1690 - 08063		x63		40	20
1690 - 08080		x80		50	25
1690 - 08100		x100		63	30
1690 - 08125		x125		75	35
1690 - 08160		x160		100	45
1690 - 10050	M10	x50	13	25	25
1690 - 10063		x63		32	35
1690 - 10080		x80		50	40
1690 - 10100		x100		75	50
1690 - 10125		x125		75	60
1690 - 10160		x160		100	80
1690 - 10200	x200	125	100		
1690 - 12050	M12	x50	15	25	35
1690 - 12063		x63		32	45
1690 - 12080		x80		50	55
1690 - 12100		x100		63	70
1690 - 12125		x125		75	90
1690 - 12160		x160		100	115
1690 - 12200	x200	125	140		
1690 - 14063	M14	x63	14	32	95
1690 - 14080		x80		50	90
1690 - 14100		x100		63	95
1690 - 14125		x125		75	120
1690 - 14160		x160		100	150
1690 - 14200		x200		125	195
1690 - 14250	x250	160	240		
1690 - 16063	M16	x63	19	32	85
1690 - 16080		x80		50	105
1690 - 16100		x100		63	130
1690 - 16125		x125		75	160
1690 - 16160		x160		100	220
1690 - 16200		x200		125	280
1690 - 16250	x250	160	325		
1690 - 16315	x315	180	425		
1690 - 16500	x500	315	650		
1690 - 18080	M18	x80	23	50	130
1690 - 18100		x100		60	160
1690 - 18125		x125		75	200
1690 - 18160		x160		100	260
1690 - 18200		x200		125	320
1690 - 18250		x250		150	400
1690 - 18315	x315	180	500		

Sipariş No	d	L	b1	b	(g)
1690 - 20080	M20	x80	27	32	190
1690 - 20100		x100		60	220
1690 - 20125		x125		70	260
1690 - 20160		x160		100	330
1690 - 20200		x200		125	410
1690 - 20250		x250		160	510
1690 - 20315	x315	200	640		
1690 - 20400	x400	250	815		
1690 - 20500	x500	315	1020		
1690 - 22100	M22	x100	31	45	270
1690 - 22125		x125		60	330
1690 - 22160		x160		100	430
1690 - 22200		x200		125	500
1690 - 22250		x250		160	670
1690 - 22315		x315		180	790
1690 - 22400	x400	250	1070		
1690 - 24100	M24	x100	35	45	290
1690 - 24125		x125		70	380
1690 - 24160		x160		100	470
1690 - 24200		x200		125	580
1690 - 24250		x250		160	730
1690 - 24315		x315		200	920
1690 - 24400	x400	250	1160		
1690 - 24500	x500	315	1450		
1690 - 24630	x630	315	1650		
1690 - 30125	M30	x125	43	56	600
1690 - 30200		x200		125	950
1690 - 30250		x250		160	1230
1690 - 30315		x315		200	1500
1690 - 30500		x500		315	2360
1690 - 30700		x700		400	3300
1690 - 301000	x1000	400	4700		
1690 - 36160	M36	x160	51	80	1100
1690 - 36200		x200		125	1340
1690 - 36250		x250		160	1710
1690 - 36315		x315		200	2150
1690 - 36400		x400		250	2700
1690 - 36500		x500		315	3450
1690 - 36700	x700	400	4750		
1690 - 42315	M42	x315	59	200	2950
1690 - 42400		x400		250	3750
1690 - 42500		x500		315	4690

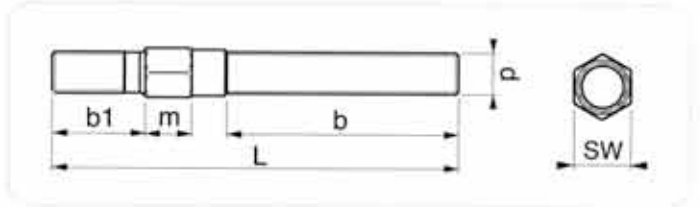



Anahtar Ağızlı Saplama

Sipariş No	d	L	b	b1	m	sw	(g)
1670 - 12130	M12	130	65	24	14	14	160
1670 - 12160		160	90				185
1670 - 14130	M14	130	65	28	15	15	216
1670 - 14160		160	90				246
1670 - 16140	M16	130	70	32	16	17	295
1670 - 16160		160	95				340
1670 - 18150	M18	150	70	35	19	19	395
1670 - 18180		180	95				450

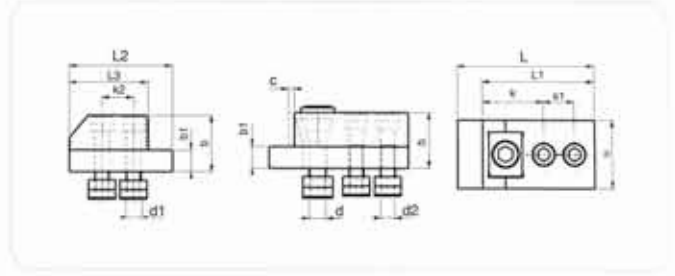

Sipariş No	d	L	b	b1	m	sw	(g)
1670 - 20150	M20	150	70	40	22	22	500
1670 - 20180		180	95				565
1670 - 22150	M22	150	70	40	22	24	650
1670 - 22180		180	95				900
1670 - 24170	M24	170	75	47	22	27	850
1670 - 24205		205	105				1025
1670 - 24250		250	140				1200



Dereceli Yandan Sıkma Paralelli Set

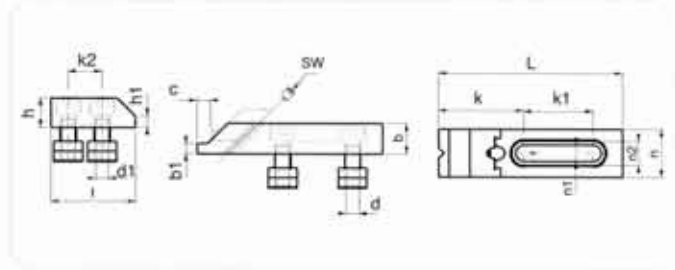

Sipariş No		c	L	L1	L2	L3	b	b1 ±0,01	n	k	k1	k2	d	d1	d2	sıkma kuvveti clamping force kgf	
2050-14	14	5	110	90	85	65	41	18	47	47	26	26	M12	M12	M12	2000	7000
2050-16	16																
2050-18	18																
2050-20	20	5	115	95	85	65	46	18	57	52	26	26	M14	M12	M12	2500	8800
2050-22	22																
2050-24	24																
2050-28	28																

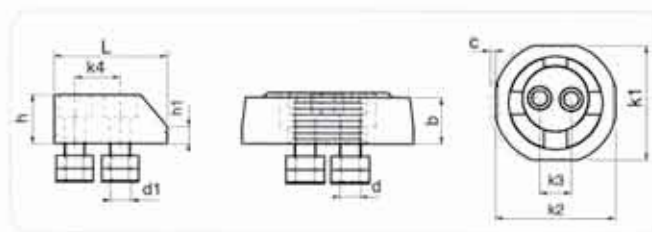

Sipariş No		c	L	b	b1	n	n1	n2	k	k1	k2	sw	i	h	h1	d	d1	sıkma kuvveti clamping force kgf	
2070-14	14	10	142	23	8	37	12.5	19	65	54	26	6	65	23	10	M12	M12	600	3650
2070-16	16																		
2070-18	18	14	145	28	10	48	12.5	19	74	54	26	8	65	28	11	M12	M12	800	4300
2070-20	20																		
2070-22	22																		



Kollu Yandan Sıkma Set

Sipariş No		c	b	k1	k2	k3	k4	L	h	h1	d	d1	sıkma kuvveti clamping force kgf	
2090-14	14	3.5	30	95	99	26	26	65	28	10	M12	M12	3500	7608
2090-16	16													7630
2090-18	18													7660
2090-20	20													7710
2090-22	22													7770
2090-24	24													7870
2090-28	28													7990

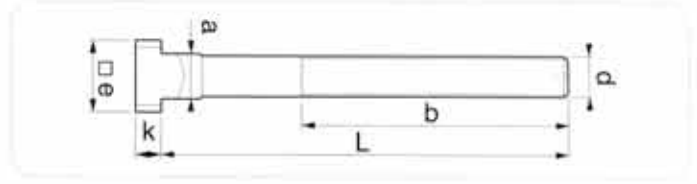

Somunlu Pullu T Ayaklı Saplama

Sipariş No.	dx	xL	b	a	e	k	(g)
1610 - 1010040	M10x10	x40	30	9,7	15	6	65
1610 - 1010063		x63	45				80
1610 - 1010080		x80	50				90
1610 - 1010100		x100	60				110
1610 - 1012050		x50	35				100
1610 - 1012063	M10x12	x63	40	11,7	18	7	120
1610 - 1012080		x80	55				130
1610 - 1012100		x100	60				150
1610 - 1012125		x125	75				175
1610 - 1012160		x160	90				225
1610 - 1012200		x200	120				270
1610 - 1212050		x50	35				120
1610 - 1212063	M12x12	x63	40	11,7	18	7	128
1610 - 1212080		x80	55				130
1610 - 1212100		x100	65				145
1610 - 1212125		x125	75				170
1610 - 1212160		x160	100				195
1610 - 1212200		x200	120				220
1610 - 1214050		x50	35				130
1610 - 1214063	M12x14	x63	45	13,7	22	8	145
1610 - 1214080		x80	55				155
1610 - 1214100		x100	65				165
1610 - 1214125		x125	75				180
1610 - 1214160		x160	100				210
1610 - 1214200		x200	120				240
1610 - 1416063		M14x16	x63				45
1610 - 1416080	x80		55	220			
1610 - 1416100	x100		65	230			
1610 - 1416125	x125		75	280			
1610 - 1416160	x160		100	310			
1610 - 1416200	200		120	350			
1610 - 1416250	250		150	400			
1610 - 1616063	M16x16	x63	45	15,7	25	9	250
1610 - 1616080		x80	55				275
1610 - 1616100		x100	65				290
1610 - 1616125		x125	85				300
1610 - 1616160		x160	100				420
1610 - 1616200		x200	125				435
1610 - 1616250		x250	150				530
1610 - 1618063	M16x18	x63	45	17,7	28	10	260
1610 - 1618080		x80	55				305
1610 - 1618100		x100	65				315
1610 - 1618125		x125	85				360
1610 - 1618160		x160	100				390
1610 - 1618200		x200	125				448
1610 - 1618250		x250	150				560
1610 - 1820080	M18x20	x80	55	19,7	32	12	420
1610 - 1820100		x100	65				460
1610 - 1820125		x125	85				490
1610 - 1820160		x160	110				580
1610 - 1820200		x200	125				610
1610 - 1820250		x250	150				700
1610 - 1820315		x315	190				930

Sipariş No.	dx	xL	b	a	e	k	(g)
1610 - 2020080	M20x20	x80	55	19,7	32	12	520
1610 - 2020100		x100	65				560
1610 - 2020125		x125	85				570
1610 - 2020160		x160	110				680
1610 - 2020200		x200	125				710
1610 - 2020250		x250	160				800
1610 - 2020315		x315	190				1030
1610 - 2022080	M20x22	x80	55	21,7	35	14	530
1610 - 2022100		x100	65				610
1610 - 2022125		x125	85				670
1610 - 2022160		x160	110				710
1610 - 2022200		x200	125				720
1610 - 2022250		x250	150				890
1610 - 2022315		x315	190				1050
1610 - 2224080	M22x24	x80	55	23,7	40	16	900
1610 - 2224100		x100	65				960
1610 - 2224125		x125	85				1020
1610 - 2224160		x160	110				1250
1610 - 2224200		x200	125				1400
1610 - 2224250		x250	150				1600
1610 - 2224315		x315	190				1700
1610 - 2424100	M24x24	x100	70	23,7	40	16	910
1610 - 2424125		x125	85				970
1610 - 2424160		x160	110				1040
1610 - 2424200		x200	125				1265
1610 - 2424250		x250	150				1410
1610 - 2424315		x315	190				1640
1610 - 2424400		x400	240				1780
1610 - 2428100	M24x28	x100	70	27,7	44	18	980
1610 - 2428125		x125	85				1010
1610 - 2428160		x160	110				1150
1610 - 2428200		x200	125				1240
1610 - 2428250		x250	150				1500
1610 - 2428315		x315	190				1730
1590 - 2428400		x400	240				1860
1610 - 2428500	x500	290	2310				
1610 - 3036125	M30x36	x125	80	35,6	54	22	1860
1610 - 3036160		x160	110				1950
1610 - 3036200		x200	135				2230
1610 - 3036250		x250	150				2550
1610 - 3036315		x315	200				2950
1610 - 3036500		x500	300				3950
1610 - 3642160		M30x42	x160				100
1610 - 3642250	x250		175	3840			
1610 - 3642400	x400		250	4950			
1610 - 3642600	x600		340	6500			
1610 - 4248160	M42x48	x160	100	47,6	75	30	6000
1610 - 4248250		x250	175				6900
1610 - 4248400		x400	250				8100

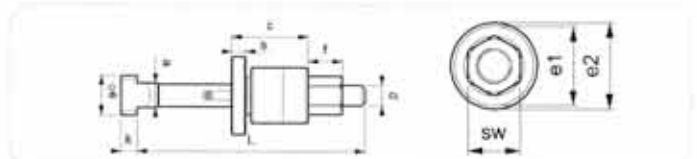

Kombine T Ayaklı Saplama

Sipariş No.	dx	xL	a	e	k	h-H	e1	e2	c	s	f	sw	(g)
1630 - 2022200	M20x22	200	21,7	35	14	25 - 75	49	69	92	11	30	30	1550
1630 - 2022250		250				70 - 120							1800
1630 - 2424200	M24x24	200	23,7	40	16	25 - 75	53	74	92	12	30	36	1900
1630 - 2424250		250				70 - 120							2100
1630 - 2428200	M24x28	200	27,7	44	18	25 - 75	53	74	92	12	30	36	2200
1630 - 2428250		250				70 - 120							2500
1630 - 3036200	M30x36	200	35,7	54	22	25 - 75	68	88	94	14	30	36	3250
1630 - 3036250		250				70 - 120							3500

Destek Delikli Düz Pabuç

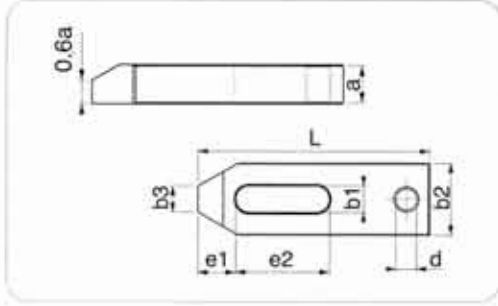

Sipariş No.	L	b1	metrik		a	b2	b3	e1	e2	d	g
			metrik	whitworth							
1330-06050	50	6,6	M6	1/4	10	20	8	10	20	M8	60
1330-08060	60	9	M8	5/16	12	25	10	13	22	M8	110
1330-10080	80	11	M10	3/8	15	30	12	15	30	M10	200
1330-12100	100	14,5	M12-M14	1/2	20	40	14	21	40	M12	550
1330-12125	125								50		550
1330-16125	125	18,5	M16-M18	5/8	25	50	18	26	45	M16	1100
1330-16160	160								65		1330
1330-20160	160				30	60			60		2000
1330-20200	200	22,5	M20-M22	3/4	30	60	22	30	80	M20	2200
1330-20250	250				35	70			100		2500
1330-24160	160				30	70	26		60		1900
1330-24200	200				35	70	26		80		2500
1330-24250	250	26	M24	1	35	70	26	35	100	M24	3750
1330-24315	315				40	80	35		130		4200
1330-30250	250	33	M30	1 1/4	40	80	34	45	100	M24	4800
1330-30315	315				50				130		7600
1330-36400	400	43	M36-M42	1 1/2	60	100	43	100	150	M24	17800

Merdiven Dış Bağlama Pabuçu

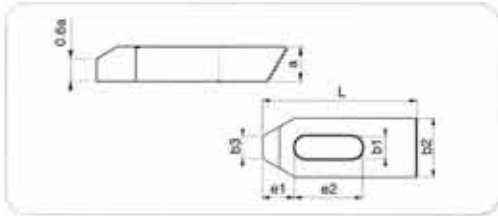

Sipariş No.	L	b1	metrik		a	b2	b3	e1	e2	g
			metrik	whitworth						
1290-06050	50	6.6	M6	1/4	10	20	8	10	20	50
1290-06080	80								30	80
1290-08060	60	9	M8	5/16	12	25	10	13	22	90
1290-08100	100								45	170
1290-10080	80	11	M10	3/8	15	30	12	15	30	190
1290-10100	100								45	340
1290-12100	100	14.5	M12-M14	1/2	20	40	14	21	45	450
1290-12125	125								55	600
1290-16125	125	18.5	M16-M18	5/8	25	50	18	26	55	800
1290-16160	160								65	1400

Destek Delikli Z Bağlama Pabuçu

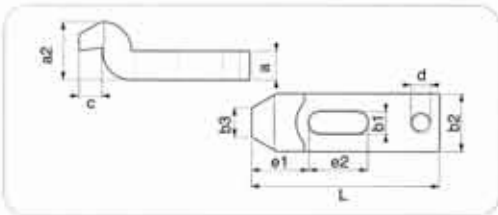

Sipariş No.	L	b1	metrik		a	b2	b3	c	e1	e2	d	g
			metrik	whitworth								
1450-06060	60	6.6	M6	1/4	10	20	10	8	20	20	M8	80
1450-08080	80	9	M8	5/16	12	25	12	9	25	25	M8	160
1450-10100	100	11	M10	3/8	15	30	15	12	32	32	M10	300
1450-12125	125	14.5	M12-M14	1/2	20	40	20	16	40	40	M12	570
1450-16125	125	18.5	M16-M18	5/8	25	50	25	20	49	40	M16	980
1450-16160	160								50	50		1150
1450-20160	160	22.5	M20-M22	3/4	30	60	30	24	55	55	M20	1800
1450-20200	200								70	70		2150
1450-24160	160								53	55		2100
1450-24200	200	26	M24	1	35	70	35	28	72	60	M24	2560
1450-24250	250								72	80		3100
1450-30250	250	33	M30	1 1/4	40	80	40	40	91	80	M24	5400
1450-30315	315				50				100	100		9000

Kombine Bağlama Pabuçu



Sipariş No.	a	h min - max	f	c	L	b	g
1250 - 01	14-16-18-20-22	55-110	3	17	110	38	1500
1250 - 02		80-137	3	17	110	38	1750
1250 - 03		125-224	3	17	110	38	2500
1250 - 04		160-300	3	17	110	38	3200

Kademeli Destek Delikli Bağlama Pabuç



Sipariş No.	L	b1	metrik		a	b2	a1xa2	b3	e1	e2	d	g
			metrik	whitworth								
1370-10080	80	11	M10	3/8	15	30	5x8	12	15	30	M10	200
1370-12100	100	14.5	M12-14	1/2	20	40	8x10	14	21	40	M12	470
1370-12125	125											610
1370-16125	125	18.5	M16-18	5/8	25	50	10x12.5	18	26	45	M16	960
1370-16160	160											1190
1370-26160	160	22.5	M20-22	3/4	30	60	12x15	22	30	60	M20	1730
1370-20200	200											2140
1370-24160	160	26	M24	1	30	70	12x15	26	35	60	M24	1900
1370-24200	200				35		14x17			80		2500
1370-24250	250				35		14x17			100		3700

Çatal Pabuç



Sipariş No.	L	b1	metrik		a	b2	b3	b4	g	
			metrik	whitworth						
1390-06060	60	6.6	M6	1/4	12	19	6	3	60	
1390-08080	80	9	M8	5/16	15	25	8	4	140	
1390-10100	100	11	M10	3/8	20	31	10	5	300	
1390-12125	125	14.5	M12-M14	1/2	25	38	12	6	570	
1390-12160	160								730	
1390-12200	200								910	
1390-16160	160	18.5	M16-M18	5/8	30	48	15	8	1080	
1390-16200	200				30				8	1360
1390-16250	250				40				10	2250
1390-20200	200	22.5	M20-M22	3/4	40	52	15	10	1800	
1390-20250	250				40				20	3000
1390-20315	315				40				20	3850
1390-20500	500				50				20	7500
1390-24200	200				26				M24	1
1390-24250	250	40	3000							
1390-24315	315	40	3850							
1390-24500	500	50	7600							
1390-30250	250	33	M30	1 1/4	50	74	20	12	3700	
1390-30315	315				50				20	4750
1390-30400	400				50				20	6100
1390-30600	600				50				20	9200
1390-301000	1000				60				30	28000
1390-36400	400	40	M36	1 1/2	60	100	30	12	11000	
1390-36600	600								16500	
1390-42600	600	43	M42	1 1/2	80	123	40	12	29600	



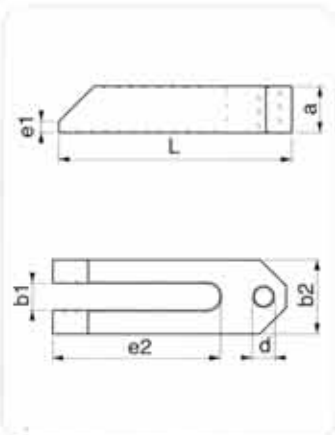



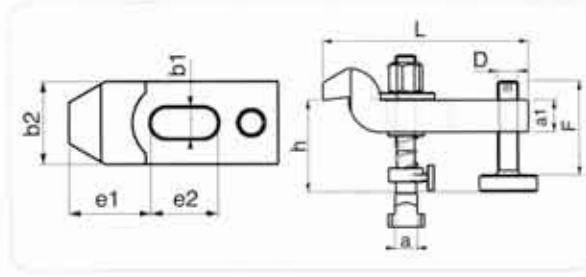





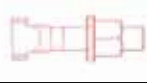

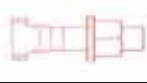

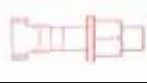

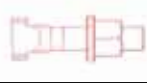

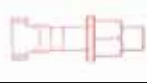

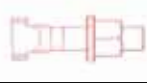
Destek Delikli Çatal Pabuç

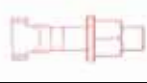

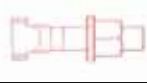
Sipariş No.	L	b1	metrik		a	e1	e2	b2	d	g
			metrik	whitworth						
1410-10100	100	11	M10	3/8	20	5	70	30	M10	300
1410-12125	125	14.5	M12-M14	1/2	25	6	90	40	M12	600
1410-16160	160	18.5	M16-M18	5/8	30	8	110	50	M16	1200
1410-20200	200	22.5	M20-M22	3/4	40	10	135	60	M20	2900

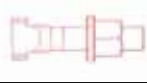

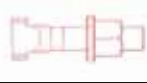
**Ayarlanabilir
Destek Civatalı
Kombine Bağlama Z Pabuç**

Sipariş No.		L		a1	b2	e1	e2	b1		h		D x F	
1190-1010100	10	100		15	30	32	32	11		26-50		M10x42	350
1190-1212125	12	125		20	40	40	40	14.5		33-60		M12x50	700
1190-1214125	14	125		20	40	40	40	14.5		37-60		M12x50	750
1190-1616160	16	160		25	50	49	50	18.5		41-75		M16x62	1300
1190-1618160	18	160		25	50	49	50	18.5		41-75		M16x62	1500
1190-2020200	20	200		30	60	55	70	22.5		46-75		M20x62	2500
1190-2022200	22	200		30	60	55	70	22.5		46-75		M20x62	2700
1190-2424200	24	200		35	70	72	60	26		52-95		M24x81	3800
1190-2428200	28	200		35	70	72	60	26		52-95		M24x81	4000



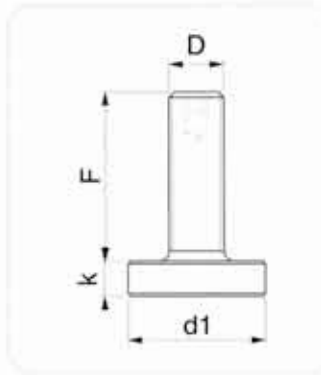

Pabuç Destek Civatası

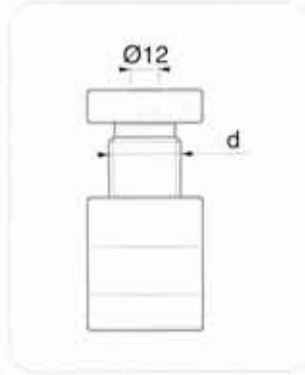

Sipariş No.	D x F	d1	k	
1490-10042	M10x42	30	8	60
1490-12050	M12x50	36	10	100
1490-12095	M12x95	36	10	150
1490-16062	M16x62	45	13	200
1490-16097	M16x97	45	13	250
1490-16117	M16x117	45	13	300
1490-20062	M20x62	50	13	340
1490-20097	M20x97	50	13	400
1490-20117	M20x117	50	13	430
1490-24081	M24x81	50	14	600
1490-24116	M24x116	50	14	850



Trapez Diş Yükseltici

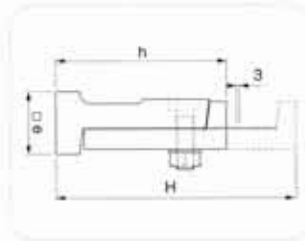

Sipariş No.		d				kgf	
1510-023030	23-30	M16	34	32	1000	140	
1510-040060	40-60	M16	34	32	1800	250	
1510-042052	42-52	Tr 30x4	50	50	6000	550	
1510-050070	50-70	Tr 30x4	50	50	6000	620	
1510-070100	70-100	Tr 30x4	50	50	6000	900	
1510-100140	100-140	Tr 30x4	50	50	6000	1600	
1510-140220	140-220	Tr 30x4	54	54	6000	2400	
1510-210330	210-330	Tr 30x6	58	58	5000	3900	
1510-260430	260-430	Tr 30x6	68	68	4000	6700	

Merdiven Diş Kombine Destek



Sipariş No.	h-H	e		
1585-050	110-150	50	4000	1300
1585-060	150-220	60	5000	2600
1585-080	220-340	80	6000	6000

Pul

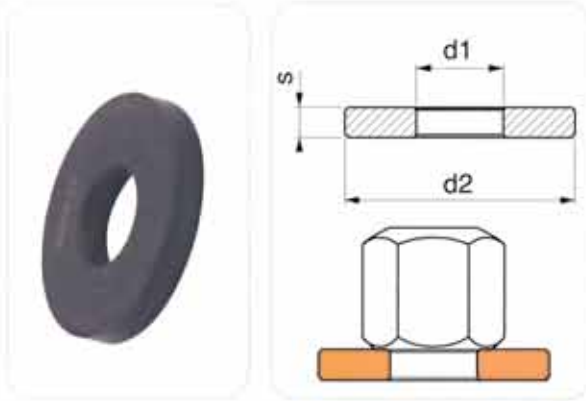

Sipariş No.	metrik		d	d2	s	(g)
	metrik	whitworth				
1870-06	M6	1/4	6.4	17	3	6
1870-08	M8	5/16	8.4	23	4	10
1870-10	M10	3/8	10.5	28	4	16
1870-12	M12	1/2	13	35	5	35
1870-14	M14	-	15	40	5	40
1870-16	M16	5/8	17	45	6	60
1870-18	M18	-	19	50	6	60
1870-20	M20	3/4	21	50	6	75
1870-22	M22	7/8	23	50	8	95
1870-24	M24	7/8	25	60	8	170
1870-30	M30	11/8	31	68	10	230
1870-36	M36	11/4	38	80	12	350

Dereceli Pul

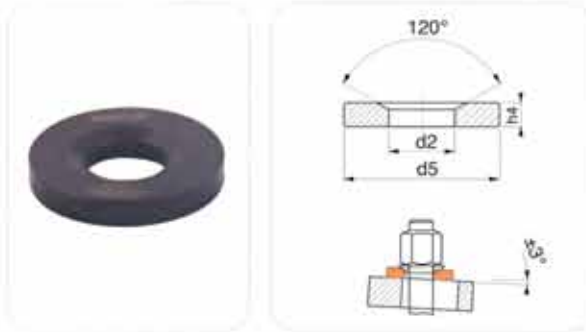

Sipariş No.		d2	d5	h4	(g)
1930-06	M6	7.1	17	4	5.5
1930-08	M8	9.6	23	4	13
1930-10	M10	12	30	5	19
1930-12	M12	14.2	35	5	32
1930-14	M14	16.5	40	5	50
1930-16	M16	19	45	6	55
1930-20	M20	23.2	50	8	95
1930-24	M24	28	60	10	170
1930-30	M30	35	68	10	220
1930-36	M36	42	80	12	350

Radyüslü Pul



Sipariş No.		d1	d3	h2	r	(g)
1890-06	M6	6.4	12	2.3	9	1.5
1890-08	M8	8.4	17	3.2	12	2.5
1890-10	M10	10.5	21	4.0	15	5
1890-12	M12	13	24	4.6	17	7
1890-14	M14	15	28	5.0	22	10
1890-16	M16	17	30	5.3	22	15
1890-20	M20	21	36	6.3	27	25
1890-24	M24	25	44	8.2	32	45
1890-30	M30	31	56	11.2	41	85
1890-36	M36	37	68	14.0	50	185

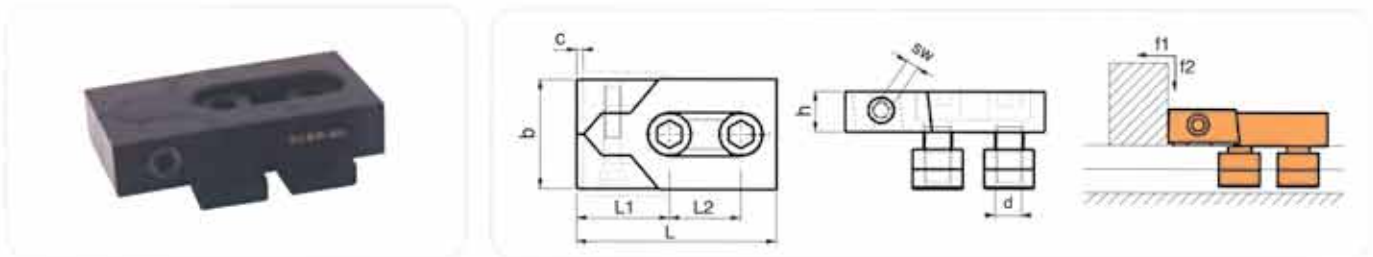



Çift Çeneli Yandan Sıkma Pabucu

Sipariş No.	a	c	h	b	L	L1	L2	sw	d	Sıkma Kuvveti Clamping Force		(g)
										f1 kgf	f2 kgf	
2110-12	12	3	20	40	80	39	26	6	M10	1600	60	560
2110-14	14									2200	90	610
2110-16	16	4	25	50	100	46	34	8	M14	3200	120	1200
2110-18	18									3600	140	1300
2110-20	20									3600	140	1325
2110-22	22	5	30	78	140	65	50	10	M20	3600	140	2995
2110-24	24									3600	140	3200
2110-28	28									4000	160	3600

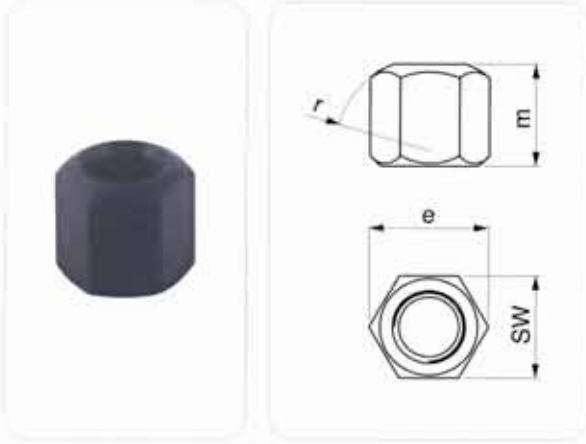

Takviyeli Somun



Sipariş No.		sw	e	m	r	
1790-06	M6	10	11.5	9	9	5
1790-08	M8	13	15	12	12	9
1790-10	M10	17	19.6	15	15	14
1790-12	M12	19	21.9	18	17	20
1790-14	M14	22	25.4	21	20	45
1790-16	M16	24	27.7	24	22	60
1790-18	M18	27	31.2	27	24	85
1790-20	M20	30	34.6	30	27	110
1790-22	M22	32	36.9	33	30	130
1790-24	M24	36	41.5	36	32	200
1790-30	M30	46	53.1	45	41	400
1790-36	M36	55	63.5	54	50	720

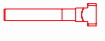

Pullu Somun



Sipariş No.		sw	e	m	a	d1	
1810-08	M8	13	15	12	3.5	18	12
1810-10	M10	17	19.7	15	4	22	25
1810-12	M12	19	21.9	18	4	25	35
1810-14	M14	22	25.4	21	4.5	28	50
1810-16	M16	24	27.7	24	5	31	70
1810-18	M18	27	31.2	27	5	34	95
1810-20	M20	30	34.6	30	6	37	130
1810-22	M22	32	36.9	33	6	40	160
1810-24	M24	36	41.5	36	6	45	230
1810-30	M30	46	53.1	45	8	58	470



Uzatma Somun

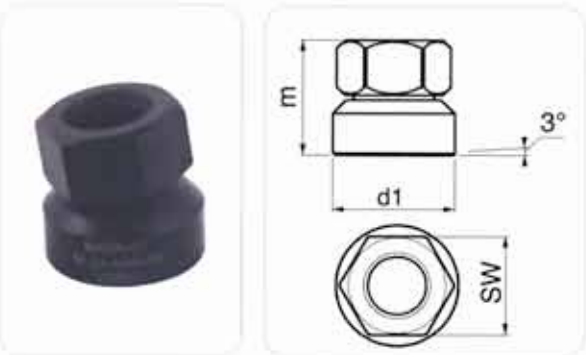

Sipariş No.		sw	e	m	
1830-06	M6	10	11.7	18	8
1830-08	M8	13	15	24	19
1830-10	M10	17	19.6	30	45
1830-12	M12	19	21.6	36	65
1830-14	M14	22	25.4	42	95
1830-16	M16	24	27.7	48	120
1830-18	M18	27	31.2	54	170
1830-20	M20	30	34.6	60	250
1830-22	M22	32	36.9	66	280
1830-24	M24	36	41.5	72	400
1830-30	M30	46	53.1	90	850
1830-36	M36	55	63.5	108	1470

Oynar Başlı Pullu Somun



Sipariş No.		sw	d1	m	
1850-08	M8	13	17	14	15
1850-10	M10	17	21	18	30
1850-12	M12	19	24	22	40
1850-16	M16	24	30	28	70
1850-20	M20	30	36	35	150
1850-24	M24	36	44	43	260

Hassas Ölçü Aletleri - Kumpaslar ve Kompratörler

Dijital Kumpas

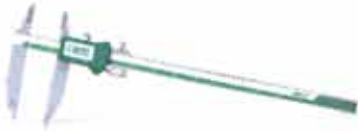

Ölçme Mesafesi (mm)	Hassasiyet (mm)
0 - 150	X 0,01
0 - 150	X 0,01
0 - 200	X 0,01
0 - 200	X 0,01
0 - 300	X 0,01
0 - 500	X 0,01

Kumpas



Ölçme Mesafesi (mm)	Hassasiyet (mm)
0 - 150	X 0,05
0 - 150	X 0,02
0 - 200	X 0,50
0 - 200	X 0,02
0 - 300	X 0,02
0 - 500	X 0,02
0 - 1000	X 0,02

Saatli Kumpas



Ölçme Mesafesi (mm)	Hassasiyet (mm)
0 - 150	X 0,02
0 - 200	X 0,02
0 - 300	X 0,02

Derinlik Kumpas



Direnç	Hassasiyet (mm)
0 - 200	X 0,05
0 - 300	X 0,02

Kulaklı Kompratör



Ölçme Mesafesi (mm)	Hassasiyet (mm)
0 - 10	X 0,01
0 - 25	X 0,01

Salgı Kompratör



Ölçme Mesafesi (mm)	Hassasiyet (mm)
0 - 0,14	X 0,001
0 - 0,8	X 0,01

Mikrometreler

Dijital Mikrometre



Ölçme Mesafesi (mm)	Hassasiyet (mm)
0 - 25	X 0,01
25 - 50	X 0,01
50 - 75	X 0,01
75 - 100	X 0,01

Dış Çap Mikrometresi



Ölçme Mesafesi (mm)	Hassasiyet (mm)
0 - 25	X 0,01
25 - 50	X 0,01
50 - 75	X 0,01
75 - 100	X 0,01

Silindir Kompratörü



Ölçme Mesafesi (mm)	Hassasiyet (mm)
10 - 18	X 0,01
18 - 35	X 0,01
35 - 60	X 0,01
50 - 150	X 0,01
100 - 160	X 0,01

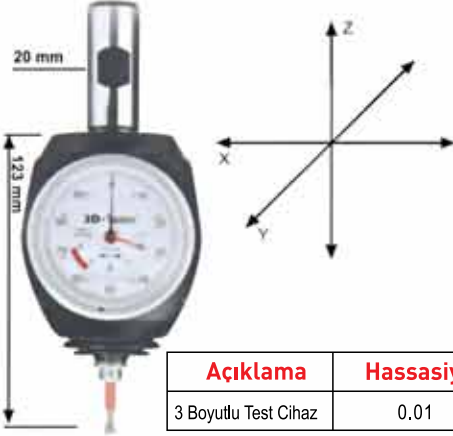

Açıklama	Hassasiyet
3 Boyutlu Test Cihaz	0,01

3D Tester (3 Boyut Ölçüm İçin)

İndikatör (Saat Ekranı) 0 (Sıfır) gösterdiğinde makinenin merkezi bulunmuş, tekrar hesaplamaya gerek yoktur. Test çubuğu x-y-z akslarında hareket edebilir veya iş parçası üzerinde, taksimat aralığı 0.01 mm. Güvenilir - hassas konstrüksyonda üretilmiştir. Test çubukları ayrıca temin edilebilir, merkezleme, köşe bulma, ölçüğe getirme, 0 noktası markalama için ideal bir cihazdır.



Açıklama	Ağırlık
4 x 33 Standart Ayak	10 gr
8 x 75 Uzun Ayak	15 gr



Z Aksı Sıfırlama (Z-50)

Z Aksı Sıfırlama (Işıklı - Elektronik)

Z Aksı Sıfırlama (Işıklı)



(Z - 50)



Işıklı Sesli Prob

Mekanik Prob

Jhonson Mastları

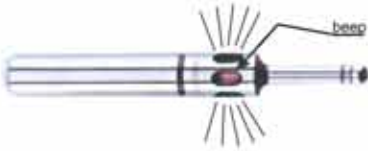

Işıklı Prob



d	d1	L	L1
10		83	
10	4	90	8



Şapkalı Gönye



Kıl Gönye

Çelik Layner

Ebat	
50 x 40 mm	250 x 165 mm
75 x 50 mm	300 x 175 mm
100 x 70 mm	400 x 230 mm
150 x 100 mm	500 x 280 mm
200 x 130 mm	

Ebat
50 x 40 mm
75 x 50 mm
100 x 70 mm
150 x 100 mm
200 x 130 mm
300 x 200 mm

Ebat	Kalınlık
13 mm	0.01mm
13 mm	0.02mm
13 mm	0.05mm
13 mm	0.08mm
13 mm	0.10mm
13 mm	0.15mm
13 mm	0.20mm
13 mm	0.30mm
13 mm	0.50mm
13 mm	0.80mm
13 mm	1.00mm
13 mm	1.50mm
13 mm	2.00mm



Manyetik Ayaklar



Model	Ölçüler	Kuvvetler	Kol Ölçü	Kg
VMB - B	62x50x55	80 Kgs	12x173	1.5
VMB - 01	62x50x55	80 Kgs	12x173	1
VMB - 70	62x50x55	100 Kgs	25x198	2
VMB - 106	75x50x55	100 Kgs	25x125	3
VMB - 106H	75x50x55	100 Kgs	25x125	1.9
VMH - 54	65x50x55	75 Kgs	16x330	1.5
VMH - 62	65x50x55	75 Kgs	16x330	1.7
VMH - 71	65x50x55	75 Kgs	15x500	1.8

Manyetik V Yatak



Model	Kuvvet	H	W	L	L1	L2	Kg
VCP-25	70 Kgs	95,3	70	101,6	50	20	4

Manyetik V Yatak (Uzun)



Model	Kuvvet	H	W	L	L1	Kg
VCP-26	30 Kgs	73	54	70	38	2,1
VCP-27	35 Kgs	75	60	125	38	3,5

Taşlanmış Kare V Yatak



Model	W1 Kuvvet	Kuvvet	H	W	L	W1	Kg
VCP-31	25 Kgs	50 Kgs	100	100	100	26	8
VCP-32	50 Kgs	140 Kgs	150	150	150	32	22

Taşlanmış Kare V Yatak



Model	Kuvvet	H	W	L	L2	Kg
VCP-29	17 Kgs	74	45	110	60	5
VCP-30	23 Kgs	100	50	150	90	5

Paralel V Yatak



Model	Ebat	Model	Ebat
PVY-001	44x41x35	PVY-002	70x44x41

Açı Ayarlı V Yatak



Model	Ebat
AVV-001	30x48x102 mm

RE-AL

KESİCİ TAKIMLARI & TEKNİK HIRDAVAT SAN. TİC.

MERKEZ

Yıldırım Mahallesi Ali Fuat Başgil Caddesi
No:116/7 Bayrampaşa/İSTANBUL
Tel : +90.212 538 61 84
Fax : +90.212 649 04 99
Gsm : +90.533 733 47 23

ŞUBE

Mimar Sinan Mahallesi Küçük Sanayi
12. Cadde 61. Sokak No.22 ÇORUM
Gsm : +90.533 652 34 55